



**TEREX**  
**LIGHT CONSTRUCTION**

**OMP16/21**  
**POWER BUGGY**  
**OPERATOR/PARTS**  
**MANUAL**

**REVISED FEBRUARY 2006**

---

**Owners, Users, and Operators:**

Terex Light Construction appreciates your choice of our machine for your application. Our number one priority is user safety, which is best achieved by our joint efforts. We feel that you make a major contribution to safety if you, as the equipment users and operators:

- 1 Comply with OSHA, Federal, State, and Local Regulations.
- 2 Read, understand and follow the instructions in this and other manuals supplied with this machine.
- 3 Use Good Safe Work Practices in a common sense way.
- 4 Only have trained/certified operators - directed by informed and knowledgeable supervision - running the machine.

NOTE: OSHA prohibits the alteration or modification of this machine without written approval of the manufacturer. Use only factory approved parts to service or repair this machine.

If there is anything in this manual that is not clear to you, or which you believe should be added, please send your comments to the Manager of Publications, Terex Light Construction 1-800-433-3026.

Thank you!

**Standards**

Many aspects of power buggy operation and testing are discussed in standards published by the American National Standards Institute. These Standards are updated on a regular basis with addenda. Terex recommends that you purchase and refer to the following standard.

ANSI B56.8 - Personnel and Burden Carriers

This Standard can be purchased from:

American National Standards Institute  
25 West 43rd Street, 4th Fl.  
New York, New York, 10036  
Tel. 212.642.4900  
Fx. 212.398.0023

## Symbols

The symbols below and the decals on the machine are used to inform the operator of important information concerning the operation of this machine.



This symbol means your safety is involved! Read, understand and follow all danger, warning and caution decals on your power buggy.



**DANGER** - Indicates an imminently hazardous situation which, if not avoided, will result in death or serious injury.



**WARNING** - Indicates a potentially hazardous situation which, if not avoided, could result in death or serious injury.



**CAUTION** - Indicates a potentially hazardous situation which, if not avoided, may result in minor or moderate injury.



**CAUTION** - Indicates a situation which, if not avoided, may result in property or equipment damage.

## Specifications



BEFORE OPERATING YOUR POWER BUGGY, READ THE MAINTENANCE, CARE, AND OPERATING INSTRUCTIONS IN THIS MANUAL.

**Models:** MPB16, MPB16E

**Wheelbase** 44"

**Overall Length** 103"

**Overall Width-dual wheels** 43.25"

**Overall Width-single wheels** 30.25"

**Overall Height** 53"

**Empty Wt.** 1200lbs.

**Ship. Wt.** Palletized 1,260 lbs.

**Bucket Capacity** 16 cu. ft. water level (.59 cu. yd.)

**Weight Capacity** - dual wheels 2500 lbs.

**Engine** 13 HP Honda, Vanguard

**Starting** Recoil or Optional Electric

**Drive Wheels** Full Hydrostatic Drive

**Speed** Up to 7.25 M.P.H. Forward and Reverse

**Steering** Handle Bars to Rear Wheels

**Brakes (drive wheels)** Dynamic Hydrostatic

**Parking Brake (drive wheels)** Mechanical

**Dump Control** Full Hydraulic Dump and Return

**Discharge Height** 5"

**Ground Clearance** 6"

**Turning Radius** 73.5"

**Tires (drive wheels)** 5.70x8x19

**Tires (steering)** 4.80x8

**Models:** MPB21

**Wheelbase** 44"

**Overall Length** 101.5"

**Overall Width-dual wheels** 43.25"

**Overall Height** 53"

**Empty Wt.** 1,375 lbs.

**Ship. Wt. Palletized** 1,465 lbs.

**Bucket Capacity** 21 cu. ft. water level (.77 cu. yd.)

**Weight Capacity** - dual wheels 3200 lbs.

**Engine** 18HP Vanguard

**Starting** Electric

**Drive Wheels** Hydrostatic

**Speed** Up to 7.25 M.P.H. Forward and Reverse

**Steering** Handle Bars to Rear Wheels

**Brakes (drive wheels)** Dynamic Hydrostatic

**Parking Brake (drive wheels)** Mechanical

**Dump Control** Full Hydraulic Dump and Return

**Discharge Height** 6"

**Ground Clearance** 6"

**Turning Radius** 73.5"

**Tires (drive wheels)** 5.70x8x19

**Tires (steering)**

## Description of Controls

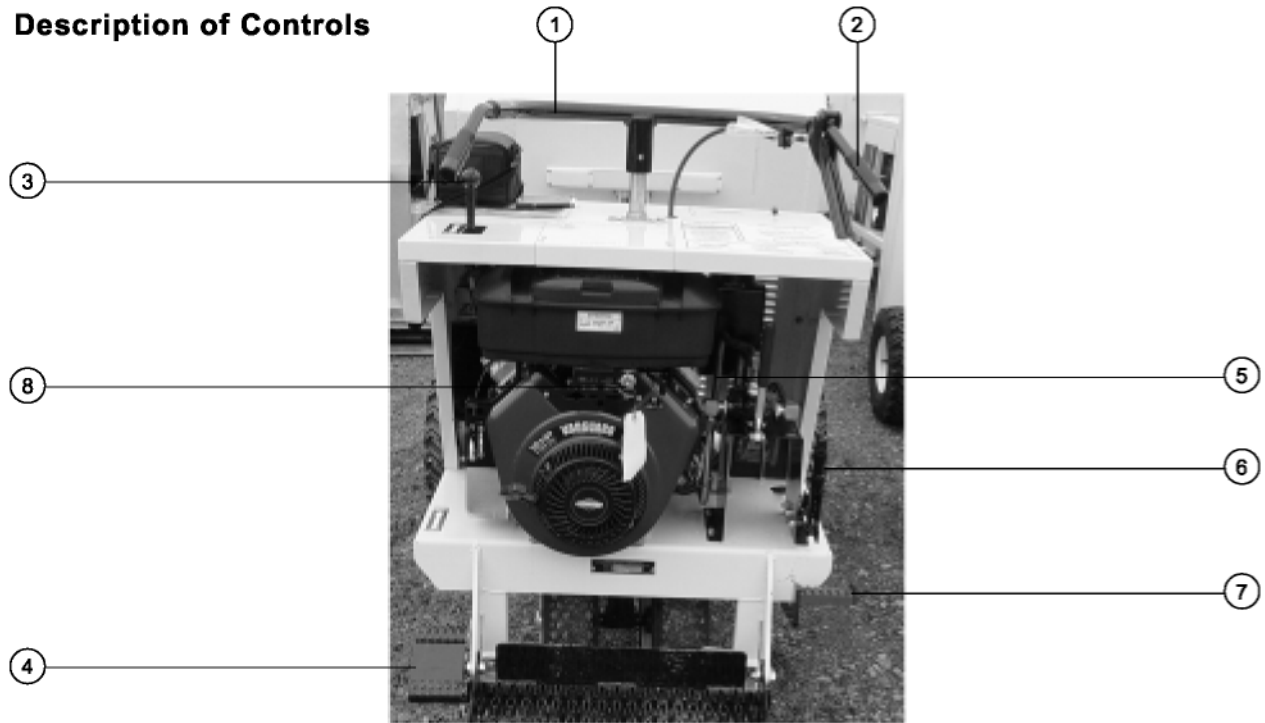

1 Steering Handle Bar - The steering handle bar is attached to the rear wheels of the unit. Rotating the handle bar clockwise steers the unit to the left. Rotating the handle bar counterclockwise steers the unit to the right.

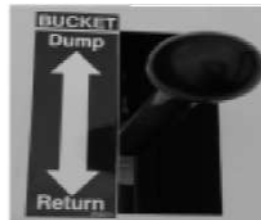

3 Dump Hand Control - The dump hand control activates the hydraulic dumping mechanism. Push forward to dump bucket. Pull back to return bucket to travel position.



2 Travel Speed Control - The travel speed control adjusts the speed at which the buggy travels. Squeeze the handle to increase speed. Release of the handle will stop the machine.

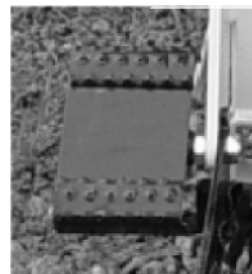

4 Dump Foot Control - The dump foot control activates the dumping mechanism. Rock the foot pedal forward to dump the bucket. Rock the pedal back to return the bucket to the travel position.

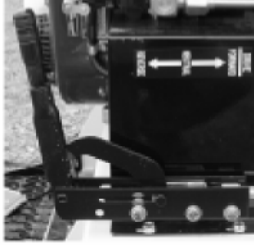

5 Travel Direction Control - The travel direction control has three positions. Push the lever forward for forward travel. The center position is for neutral. Pull the lever back for reverse.



7 Foot Brake - The foot brake activates the brake on the front axle. Push the pedal down to activate the brake. Release the pedal to release the brake.



6 Hand Parking Brake - The hand parking brake activates the parking brake on the front axle. Position the lever in the horizontal position to engage the brake. Position the lever to the vertical position to disengage the brake.



8 Engine Control - The engine control is a three position key switch. The first position (key vertical) is the stop position. The second position is the run position. The third position is the engine start position.



### Responsibilities of the Operator



Only operate this buggy if you are a qualified and authorized operator. To be qualified, you must read and understand the operating instructions, all safety signs on the buggy, have training including actual operation of the buggy and know the safety rules and regulations for the job site.

Only operate the buggy if it is in proper operating condition. Do not remove or modify any part of the buggy.

Perform Daily inspection and lubrication of buggy as outlined in the daily inspection and lubrication sections of the Operator's Manual. Report any problems immediately.

**DO NOT OPERATE THE BUGGY IF THE INSPECTION REVEALS ANY PROBLEMS.**



Wear all personal protective clothing required for the operations being performed.



## Mounting and Dismounting

Ensure the buggy is stopped before mounting or dismounting.

Prior to dismounting, ensure that all controls are in neutral and parking brake is set.



Always use “three-point contact” and face the buggy. (“Three-point contact” means that three out of four arms and legs are in contact with the buggy at all times during mount and dismount.)

Clean your shoes and wipe your hands before mounting.



Be sure to have secure footing when and wherever you step off of the machine. Never use control levers as a handhold when climbing on or off.

Never step on foot controls when climbing on or off.



## Pre-Operation Inspections

Each day, ensure that Buggy is clean and all systems are functioning properly. Report any problems immediately.

**DO NOT OPERATE THE BUGGY IF THE INSPECTION REVEALS ANY PROBLEMS.**

Before operation each day ensure the following:

- All guards, side screens and panels are in place.
- All safety and information signs are in place and legible.
- Engine and hydraulic oil levels are correct.
- Check battery level
- Check for hydraulic leaks.
- Check all operating controls for proper operation and adjustment.
- Check speed control operation before and after starting engine for proper operation.
- Confirm brake-holding capacity of buggy using the procedure outlined in the Function Test section.
- Check Tires for damage, proper inflation and security of lug nuts. (Recommended Tire Pressure: 50 psi



**SKIN INJECTION HAZARD!** Use a piece of cardboard to check for hydraulic hose leaks. **DO NOT USE YOUR HAND.** If fluid is injected under the skin, it can cause gangrene. **GET MEDICAL HELP IMMEDIATELY.**

- Fuel tank is full.



**EXPLOSION AND BURN HAZARD!** Will cause death, burns or blindness due to ignition of explosive gases or corrosive acid. Keep all open flames and sparks away. Wear personal protective equipment, including face shield, gloves and long sleeve shirt.



## Function Test

After engine has warmed to operating temperature make the following checks:

- 1 In a level, open area, with Direction Selector in Forward position, and Parking Brake engaged, check for free speed control operation. If operation of Speed Control is not free, do not attempt to operate buggy until corrected.
- 2 Set engine at idle, with Parking Brake engaged, place direction selector lever to forward position. Slowly activate speed control slightly, for a short period of time to test the Brake holding capacity. If the Power Buggy will move, adjust the Brake in accordance with the maintenance and adjustment instructions. If the Power Buggy does not move, release the speed control and disengage the Parking Brake. If Buggy tends to creep, adjust the pump control stop lever until the creeping is eliminated.
- 3 At a slow speed, operate Buggy and become familiar with its Speed Control operation, Brake operation, and Steering.



## Worksite Inspections

Check the Entire Area

Inspect the entire surface over which you will travel. Look for holes, drop offs and obstacles. Look for rough spots. On docks, ramps or floors look for weak spots. Look for oil spills, wet spots and slippery surfaces. Look for soft soil, deep mud and standing water. On rough terrain or slopes, watch for anything that might make you lose control or cause the buggy to tip over.

Inspect the grade of the path you will travel. The maximum permissible grade upon which the Power Buggy may be used is 10% (6°). Determine if any slopes on your path of travel exceed the maximum permissible grade of 10% (6°). Do not travel on any areas that are too steep.



---

## **Maximum Permissible Grades for Travel**

Fore and Aft            10% (6°)

Side to Side            10% (6°)

---

To calculate Grade, divide the vertical rise by the horizontal run and multiply by 100.

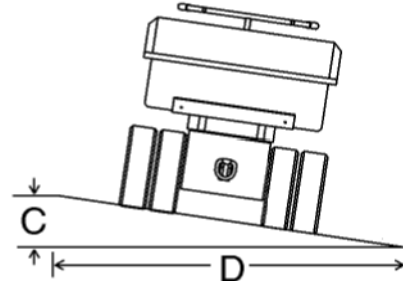
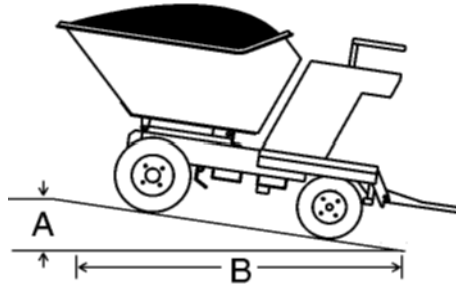

$$\% \text{ Grade} = (\text{A Divided By B}) \times 100$$

$$\% \text{ Grade} = (\text{C Divided By D}) \times 100$$

**Example Calculation:** Determine if a slope that is 2 feet high and runs 21 feet horizontally is safe to travel. Calculate % grade by executing the following.

Dimension A = 2 feet

Dimension B = 21 feet

$$\begin{aligned} \% \text{ Grade} &= (\text{A Divided By B}) \times 100 \\ &= (2 \text{ feet Divided By } 21 \text{ feet}) \times 100 \\ &= 9.5\% \end{aligned}$$

According to the calculation, this slope is safe to travel because the % grade did not exceed the maximum allowable grade of 10%. 9.5% is less than 10%.

Clear away trash and debris along travel route. Pick up anything that might puncture a tire. Make sure aisles, ramps, doorways and passages are clear. Plan your work. Make sure you know where you will make your pickups, dumps and turns. Before you pick up a load, first know your path of travel and where you will place it.

Power buggies cannot be operated in areas with flammable or explosive atmospheres.

### **Explosion Hazard**

Use of these buggies in explosive atmospheres areas can result in fires and/or explosions, which could cause serious injury or death.



### **Check Overhead**

Check the clearances of doorways, canopies and overheads. Know exactly how much clearance you have under power and telephone cables. Also check clearances when transporting your buggy on a truck or trailer.



Never approach power lines with any part of your buggy unless all local, state/provincial and federal (OSHA) required safety precautions have been taken. Use extreme caution.



## Starting Instructions

Before starting engine, refer to engine manufacturer's manual, and follow the steps below.

- 1 Engage Parking Brake.
- 2 Set Engine operating speed control to the idle position.
- 3 Check Speed Control linkage located on right handle bar. Speed Control should work freely and return to closed position when released. If operation of Speed Control is not free, do not attempt to start engine until corrected.
- 4 Turn on fuel control valve if your particular engine is so equipped.
- 5 Set Choke as recommended in the Engine Manufacturers Manual.
- 6 Pull Rope Starter or engage Electric Starter if so equipped.
- 7 When engine has started, allow to warm at an idle until operating temperature is reached before transporting or moving loads.



## General Travel

Keep personnel clear of the buggy during travel.

Do not allow anyone to stand/pass in front of the buggy during travel.

Do not approach personnel standing in front of fixed objects. Do not allow others to ride on the buggy.

Test the controls for proper operation. Be certain you can control both speed and direction before moving.

Keep both hands on the steering handle during travel.





Avoid sudden starts, stops and direction changes.

Do not operate on surfaces containing holes, drop offs, or obstacles or slopes which exceed 10% (6°) grade.

Ensure that all surfaces are capable of supporting the buggy and load.

Look for and avoid oil spills, wet or slippery surfaces that may cause loss of control.

Maintain clearances from obstacles.

Make sure aisle, ramps, doorways and passages are clear.

Clear away trash and debris. Pick up anything that may puncture a tire. If

buggy is to travel on slopes, refer to the "Travel on Slopes" section.

If buggy is to travel on uneven/rough terrain, refer to the "Travel on Uneven/Rough Terrain" section.



### **Creep Speed**

Buggy should be operated at full speed only when traveling on a flat and level surface. When traveling on surfaces that are not flat and level, DO NOT exceed a creep speed of 10 feet in 5 seconds (120 feet per minute or 1.36 miles per hour), because the buggy does not have a speedometer, always apply good judgment when determining a safe and proper creep speed.



### **Travel on Uneven/Rough Terrain**

Do not ride on buggy if the buggy is to travel on uneven/rough terrain. Instead, raise and secure the platform and walk behind the buggy. Check to make certain that the mounting bolts are sufficiently tight to retain it in that position. Do not exceed creep speed.



## Travel on Slopes



Do not travel on slopes with a loaded bucket facing downhill.

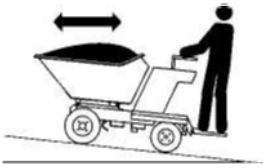

### Traveling with a loaded bucket

When traveling on slopes with a loaded bucket - ensure the bucket is positioned on the uphill end of the unit, and the operator is on the downhill end of the unit.

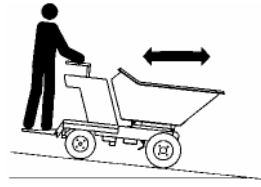

### Traveling with an unloaded bucket

When traveling on slopes with an unloaded bucket - ensure the bucket is positioned on the downhill end of the unit.

Determine if any slopes on your travel route exceed the maximum permissible grade of 10%. Do not use buggy on any slope that exceeds 10% grade.

### Maximum Permissible Grades for Travel

|              |          |
|--------------|----------|
| Fore and Aft | 10% (6°) |
| Side to Side | 10% (6°) |

To calculate Grade, divide the vertical rise by the horizontal run and multiply by 100.

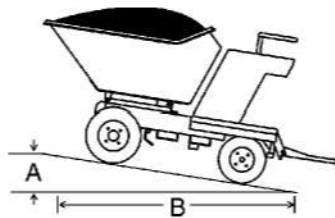

$$\% \text{ Grade} = (A \text{ Divided By } B) \times 100$$

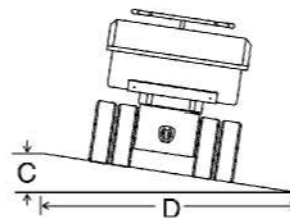

$$\% \text{ Grade} = (C \text{ Divided By } D) \times 100$$

Example Calculation: Determine if a slope that is 2 feet high and runs 21 feet horizontally is safe to travel. Calculate % grade by executing the following.

Dimension A = 2 feet

Dimension B = 21 feet

$$\begin{aligned} \% \text{ Grade} &= (A \text{ Divided By } B) \times 100 \\ &= (2 \text{ feet Divided By } 21 \text{ feet}) \times 100 \\ &= 9.5\% \end{aligned}$$

According to the calculation, this slope is safe to travel because the % grade did not exceed the maximum allowable grade of 10%. 9.5% is less than 10%.

When possible, ensure that the buggy is facing directly up/down the slope. If you must traverse across the slope, ensure that you do not exceed the permissible side-to-side slope of 10% grade.

Travel at creep speed only and ensure that stopping in a safe manner can be done at all times.

Avoid sudden starts, stops and direction changes.



### Filling/Dumping

Know the rated load capacity of the buggy. Do not exceed the capacity of the buggy, and account for conditions that can reduce the load that should be carried such as, ground conditions, slopes, etc.

If there is any question of overloading, separate the load into two or more loads.

Always use a signal person if you cannot see the placement point.

Ensure buggy is stopped and parking brake is set before filling or dumping bucket



Do not dump buggy when facing downhill on slope.



Do not stand in front of or alongside the buggy where you intend to unload.



Do not dump buggy towards other personnel.



Do not touch, lean on or reach through the dump mechanisms.



## Shutdown Instructions

Correct shutdown is important, follow these steps for safe operation.

- 1 Come to a full stop.
- 2 Set parking brake.
- 3 Idle engine for gradual cooling.
- 4 Shut off engine.
- 5 Cycle hydraulic controls to eliminate residual pressure.
- 6 Remove ignition key on electric start models.
- 7 Block wheels if on a slope or incline.

If the buggy will be exposed to wet freezing weather for a period of time, the concrete tub should be placed in the dump position so that water does not collect with the possibility of freezing and breaking the tub.



## Lifting

### Single Point Lifting:

When lifting buggy with the single point lift ring, the bucket must be in the dumped position and both lift ring support arms must be attached with retaining rings as shown.

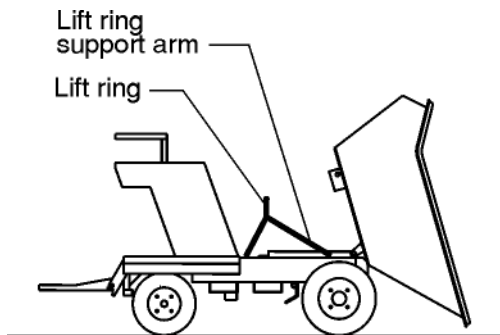

### Fork Lift Loading:

The buggy can be loaded from either side or from the rider end using the fork lift pockets provided.

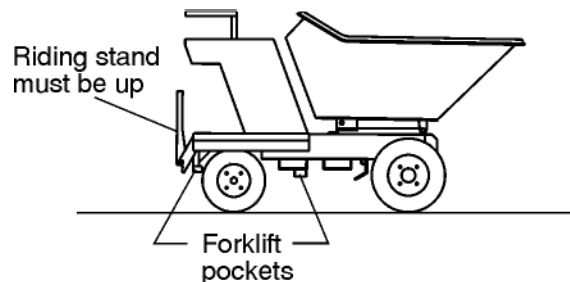

NOTE: Later models do not have the rear forklift pockets.



## Transport

When transporting the buggy on a truck or trailer, know the overall height to avoid contacting overhead obstructions such as bridges, power lines, etc. Make sure all tie-downs and blocks are in place and bucket is completely lowered and securely latched. If your buggy is to be hauled by truck, check truck and ramp capacities.

## Maintenance, Lubrication and Adjustment Engine

Check oil in your engine after every 10 hours of operation and maintain proper levels. Drain oil after every 50 hours of operation and refill with grade of oil recommended below: Above 40

Deg F. (13 Deg C.) - S.A.E. 30

Below 40 Deg F. (13 Deg C.) - S.A.E. 20

## Power Train

Check the Hydraulic Oil level in the tank, using the dip stick mounted on the filler cap and keep filled to the proper level with EXXON Nuto #H68 Hydraulic oil or equivalent. Replace after every 200 hours. The Hydraulic Oil Filter should be changed each time the Hydraulic Oil is changed.

The Hydraulic drive motors are extremely reliable and ordinarily will not need maintenance or repair. Should trouble develop in the Hydraulic drive motors, it is suggested that the dealer's service department be called. If such service is not available, from your dealer, please call TEREX Amida at (800) 433-3026 for further instructions. The Hydraulic drive motors are manufactured by White Hydraulics and may be serviced at their dealers and other service centers handling their equipment. TEREX Amida will direct you to the proper place for repairs. In the event a vibration is experienced when the engine is running, check the coupler between the engine and the Hydraulic Pump. DO NOT make this check while the engine is running, and it will be necessary to remove the fan shroud. After adjusting and tightening the coupler, REPLACE the fan shroud and then start engine to see if the problem has been corrected. DO NOT run the engine or operate the Buggy with the fan shroud removed or not firmly attached.

**COLD WEATHER NOTE:** In climates where temperatures are below 35° hard starting may occur. In these cases the oil should be switched to a thinner 15 weight hydraulic fluid.

## Chassis Lubrication

Lubricate your buggy each day of operation with a good grade of chassis lubricant at all of the lubrication points listed below. (2)

Fittings - Dump Cylinder Pivots

(4) Fittings - Tub Bearing Pivot Blocks (Underside of Tub: see page 7 & page 19)

(1) Fitting - Steering Bearing Flange (Front side of Handle Bar: see page 17)

Remove rear wheel hubs and repack bearings after every 400 hours of operation.

## Brake Adjustment

Place the Parking Brake Lever in the engaged position. The parking brake should then be adjusted so that the Buggy will not move. Adjustment is provided by a knob on the end of the Parking Brake Lever and the adjustment may be tightened by turning the knob clockwise. Adjust sufficiently tight so that when Parking Brake Lever is actuated, considerable pressure is required to place it in the over-center or "On" position.

With the Parking Brake engaged, you should not be able to move the Buggy.

## Tires

In the event you experience a puncture of the tire and tube, certain precautions must be observed in its repair, as follows:

- 1 Securely block and support the Buggy, remove lug nuts.
- 2 Repair or replace tire.
- 3 Place Wheel and Tire assembly in a suitable cage or restraint to keep it captive, then inflate tire to no more than 50 lbs. air pressure.



- 4 Reinstall on Buggy, tighten lug nuts.



**TEREX**  
LIGHT CONSTRUCTION

Model:

OMP16/21

Title:

Hydraulic Schematic

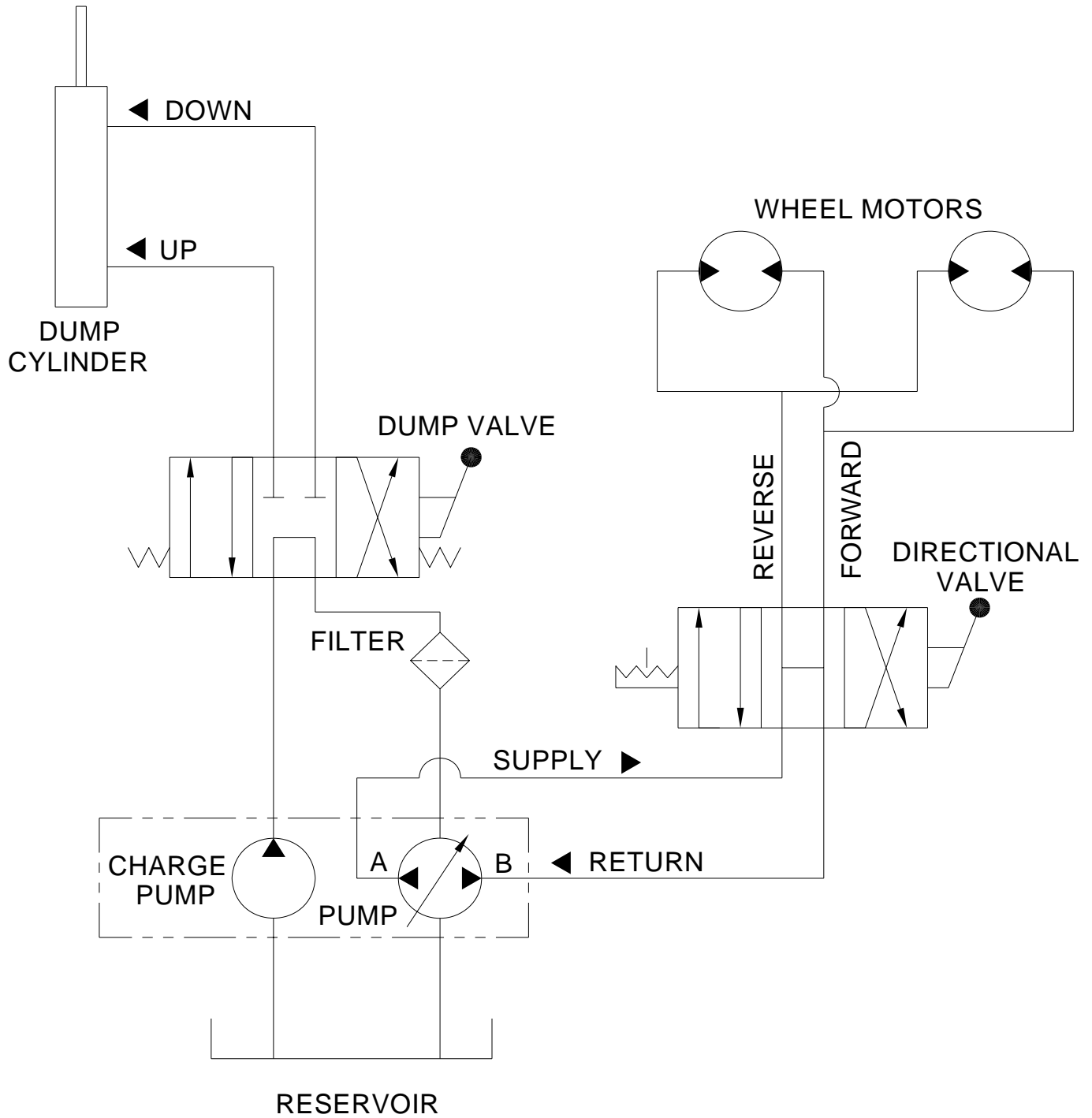

## Adjusting Valve

If the power buggy seems to be sluggish or lack power, a minor adjustment to the directional valve will probably fix the problem.

- 1) On the side of the directional valve, locate the 5/8" hex head plug and remove it. (Fig.1)
- 2) Insert a slotted screwdriver and turn the pressure relief screw clockwise until it is snug. **Do Not Over tighten!** (Fig.2)
- 3) Turn the relief valve screw counterclockwise 1/4 to 1/2 turn or set with a gauge to 2,200 p.s.i.

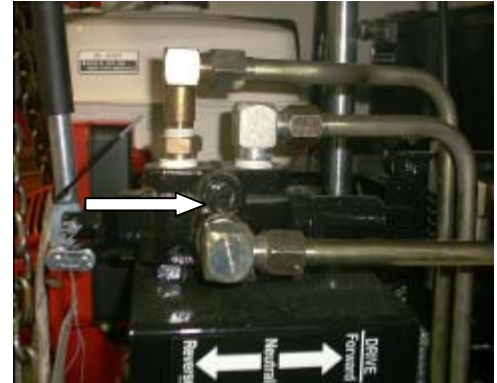

## Creep Adjustment

If the power buggy continues to travel or creep, after you have released the control lever, the pump control arm needs a minor adjustment.

- 1) Locate the pump control arm adjusting bolt. (Fig.3)
- 2) Loosen the jam nut.
- 3) Be certain that the machine is clear of any persons or debris and start the machine.
- 4) With someone standing on the operators platform, holding the emergency brake, place the directional lever into the forward position.
- 5) Slowly release the emergency brake and note the direction that the machine is creeping. If the machine creeps forward - turn the adjusting bolt downward (clockwise). If the machine creeps backward - turn the adjusting bolt upward (counterclockwise).



**NOTE:** Turning the adjusting bolt should be done in very slight increments. The pump has a neutral position of about 1/32 to 1/16 of an inch. Turning the bolt in too large of increments could cause very rapid or sudden acceleration of the power buggy.

**NOTE:** Parking brake should always be set when power buggy is stopped or parked.

**TEREX LIGHT CONSTRUCTION**

P.O. Box 3147  
Rock Hill, S.C. 29732

**MANUFACTURER'S LIMITED WARRANTY**

**TEREX LIGHT CONSTRUCTION ("TLC")** warrants to the original purchaser that such equipment, accessories, parts and other products manufactured by TLC will be free from defects in workmanship and material for a period of one (1) year after the date of first delivery or for one thousand (1,000) hours of use, whichever comes first; provided that Buyer sends TLC notice of such defect within thirty (30) days of its discovery. Should defects be discovered, the Buyer must clearly establish that (I) the equipment, parts, etc. have been properly installed and set up, maintained and operated within the limits of rated and normal usage and (II) the defect did not result in any manner from the intentional or negligent action or inaction of Buyer. Buyer must also return the defective item or items to TLC, Rock Hill, SC for inspection at TLC's request. If Buyer cannot establish that conditions (I) and (II) have been met, then this warranty shall not cover the alleged defect. Failure to give notice of defect within such period shall be a waiver of this Warranty and any assistance rendered thereafter shall not extend or revive it. **THIS WARRANTY IS LIMITED TO THE BUYER AND IS NOT ASSIGNABLE OR OTHERWISE TRANSFERABLE.**

TLC MAKES NO WARRANTY WITH RESPECT TO PARTS, COMPONENTS, EQUIPMENT AND ACCESSORIES NOT MANUFACTURED BY TLC SUCH AS FIXTURES, BALLASTS, ENGINES, HYDRAULIC PUMPS, FUEL PUMPS, ALTERNATORS, GENERATORS, WINCHES, TIRES AND ELECTRICAL COMPONENTS. Accessories, assemblies and components included in products of TLC, which are not manufactured by TLC, are subject only to the warranty of their respective manufacturers. TLC makes no other warranty, express or implied, and makes no warranty of merchantability or fitness for any particular purpose. This warranty shall not cover misuse, alteration, abuse, negligence, accident, acts of God, sabotage or any item in which serial numbers have been altered, defaced or removed, but shall be limited to repair or replacement of those parts which, upon inspection by TLC, appear to have been defective in material or workmanship.

TLC's liability and Buyer's sole and exclusive remedy for a failure of goods to perform as warranted and/or for any and all other claims arising out of the purchase and use of the goods, including negligence on the part of TLC, shall be limited to the repair or replacement of defective parts returned, transportation prepaid to TLC. TLC shall in no event be liable for incidental or consequential or other damages or losses resulting from a breach of warranty such as, but not by way of limitation, labor costs, loss of profits, loss of use of other than equipment, third party repairs, personal injury, emotional or mental distress, improper performance of work, penalties of any kind, loss of service of personnel, or any other damages or losses which may be experienced by the Buyer.

**A product warranty certificate must be filled out in its entirety and returned to TLC in order to process any warranty claims submitted.**

**THIS WARRANTY IS EXPRESSLY IN LIEU OF AND EXCLUDES ALL OTHER WARRANTIES, EXPRESSED OR IMPLIED (INCLUDING ANY WARRANTY OF MERCHANTABILITY AND FITNESS OF ANY PRODUCT OR GOODS FOR A PARTICULAR PURPOSE) AND ALL OTHER OBLIGATIONS OR LIABILITIES ON TLC'S PART, AND TLC NEITHER ASSUMES NOR AUTHORIZES ANY OTHER PERSON TO ASSUME FOR TLC ANY OTHER LIABILITY IN CONNECTION WITH THE SALE OF TLC'S PRODUCTS. THERE ARE NO WARRANTIES WHICH EXTEND BEYOND THE DESCRIPTION ON THE FACE HEREOF.**

# WARRANTY PROCEDURE

The specific language of this warranty will determine TEREX LIGHT CONSTRUCTION's obligation in connection with its product. The information presented below should be used as a general guide for implementation of policy. In the event of a component failure during the warranty period it should be repaired as soon as possible, preferably at an authorized TEREX LIGHT CONSTRUCTION service center. If component is manufactured by a company other than TEREX LIGHT CONSTRUCTION, such as Deutz, Honda, Isuzu, Leroy Somer, Lister Petter, Lombardini, Wisconsin, etc., the applicant should pursue repair and/or reimbursement through that manufacturer, and its dealer/distributor network.

To file a claim with TEREX LIGHT CONSTRUCTION, an **APPLICATION FOR WARRANTY ADJUSTMENT (AWA)** form must be completed in its entirety. Return the completed form within fourteen days of the repair to:

**ATTENTION: WARRANTY  
TEREX LIGHT CONSTRUCTION  
590 Huey Road  
Rock Hill Industrial Park  
Rock Hill, SC 29730**

TEREX LIGHT CONSTRUCTION will review the AWA form. Should we desire to inspect the defective parts, we will issue you a return authorization for the defective parts. After inspecting the defective part(s), and it is determined that warranty is due, we will then, at the discretion of TEREX LIGHT CONSTRUCTION, credit the applicants account or send replacement parts.

## TEREX LIGHT CONSTRUCTION **warranty reimbursements:**

1. \$40.00 for each hour's labor we allow toward a repair.
2. Distributors cost of parts not more than the price currently available from TEREX LIGHT CONSTRUCTION.
3. One way surface freight charges on parts returned to TEREX LIGHT CONSTRUCTION.

Many repairs are assigned a predetermined labor schedule which is an average time in which a skilled technician should be able to make a repair. TEREX LIGHT CONSTRUCTION will reimburse not to exceed the predetermined number of hours for a particular repair.

## TEREX LIGHT CONSTRUCTION **does not reimburse for:**

1. Travel, travel time, nor travel labor.
2. Mileage.
3. Excessive diagnostic time.
4. Repairs of defects, malfunctions, or failures resulting from accidents, abuse, misuse, modifications, alterations, improper servicing or lack of performance of required maintenance service.
5. Repairs where defective parts were not shipped back when requested by TEREX LIGHT CONSTRUCTION.
6. Regular maintenance such as parts or labor for oil changes, filter changes or filters.
7. Repairs where defective parts were not received by TEREX LIGHT CONSTRUCTION after TEREX LIGHT CONSTRUCTION issued a return authorization.

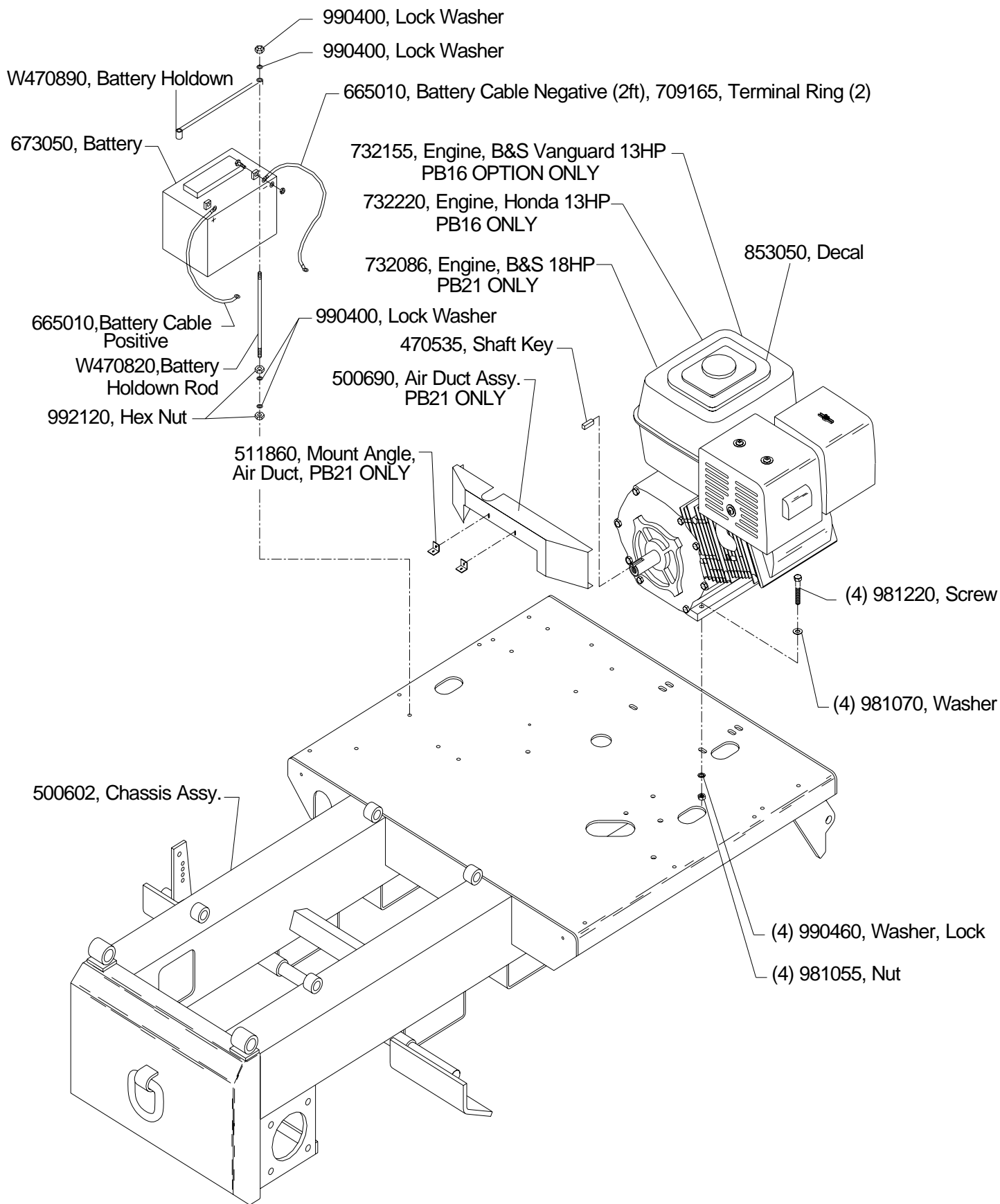



**TEREX**  
LIGHT CONSTRUCTION

Model:

0MPB16/21

Title:

Pump and Coupling

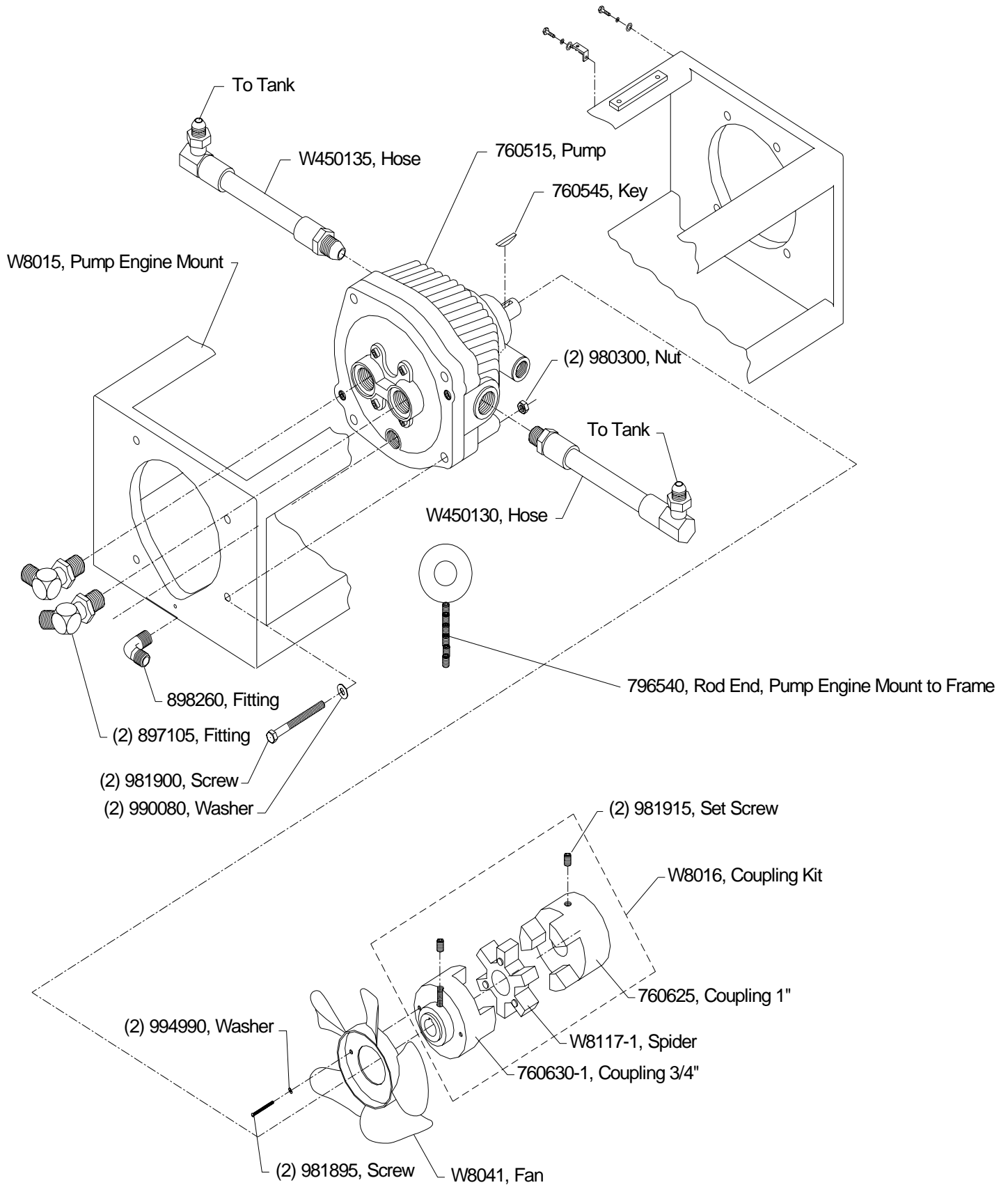



**TEREX**  
LIGHT CONSTRUCTION

Model:

OMPB16/21

Title:

Pump and Coupling

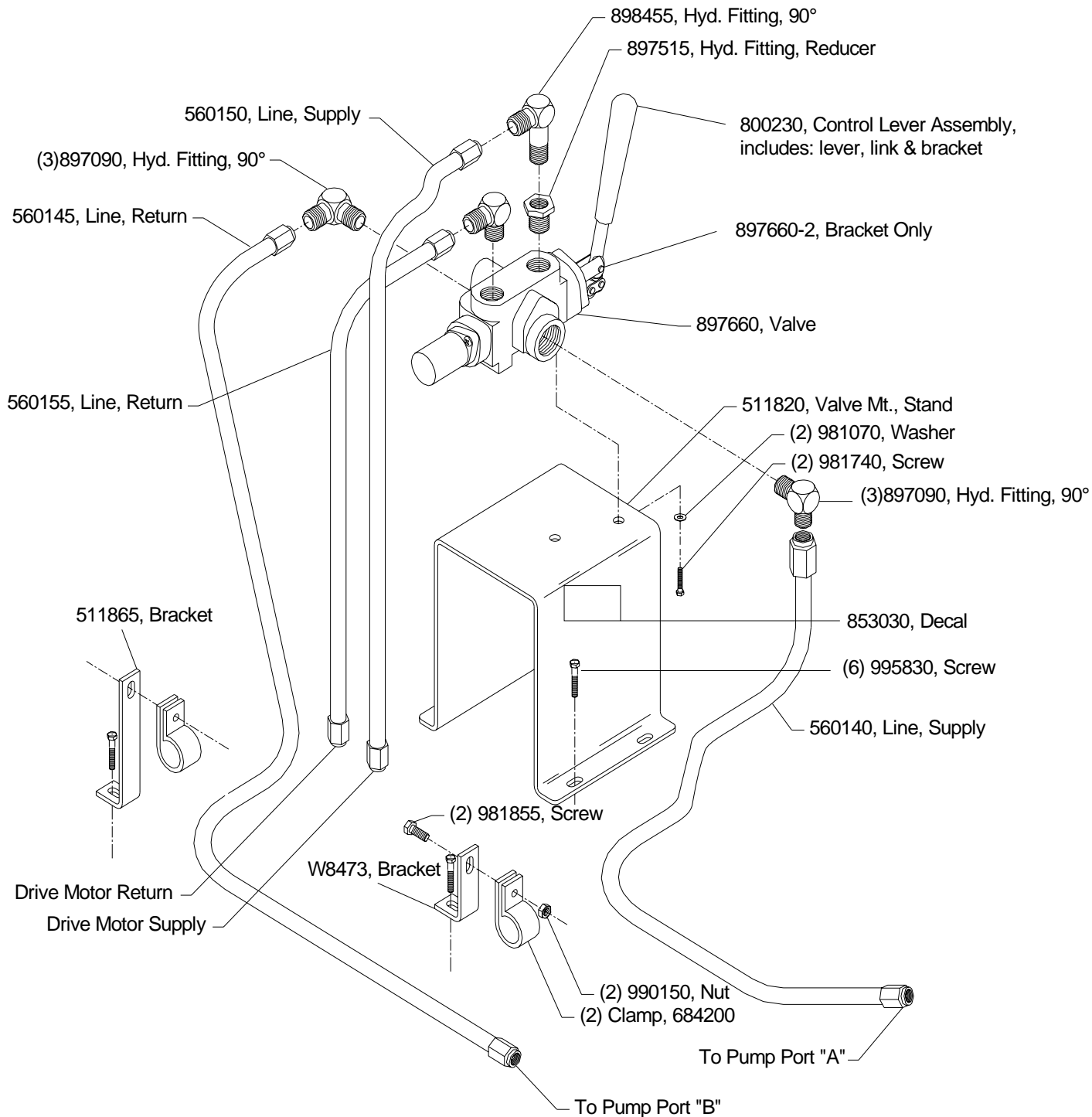

|  |        |                         |
|--|--------|-------------------------|
|  | Model: | OMP16/21                |
|  | Title: | Hydraulic Oil Reservoir |

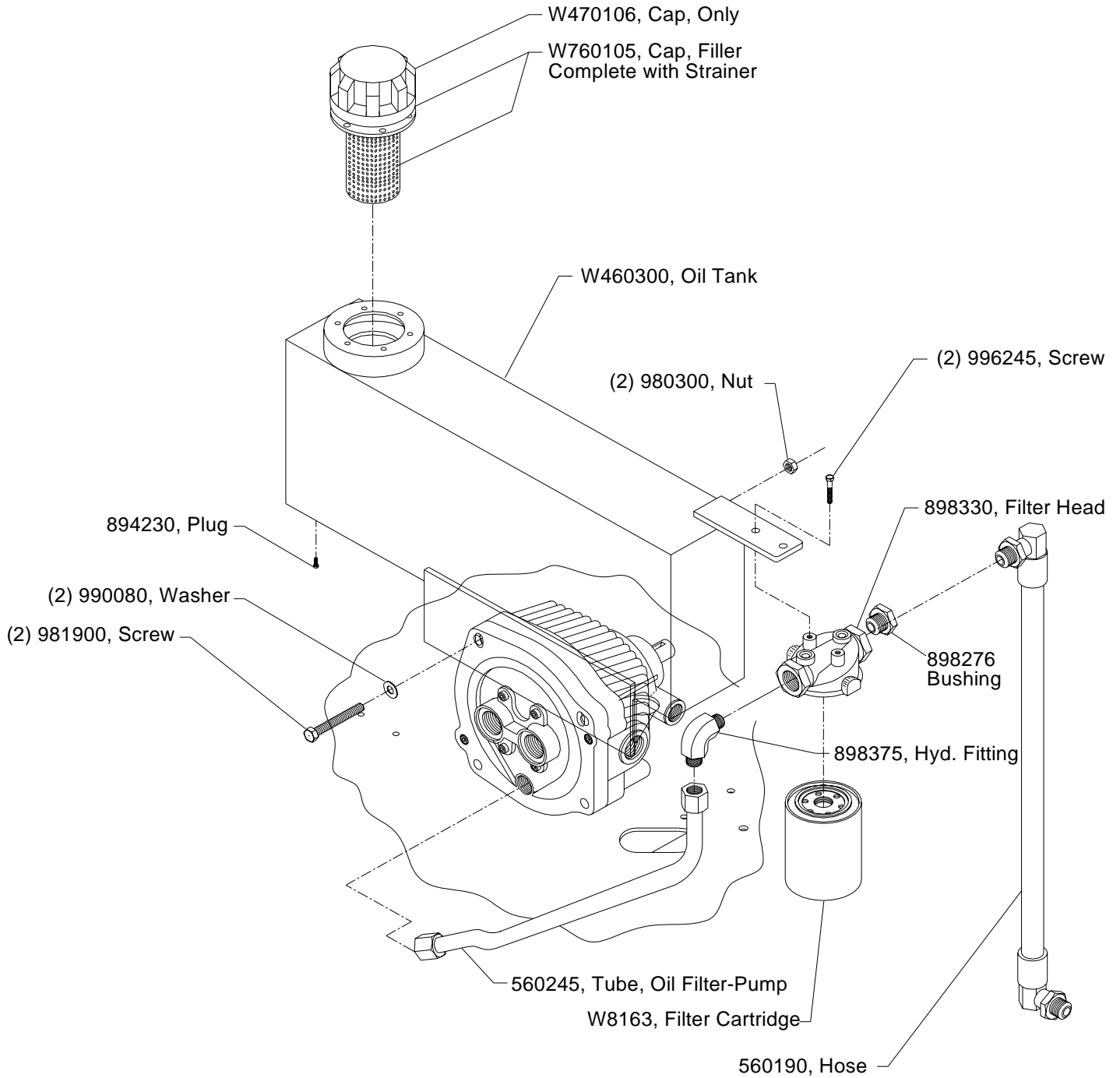



**TEREX**  
LIGHT CONSTRUCTION

Model: OMPB16/21

Title: Dump Valve

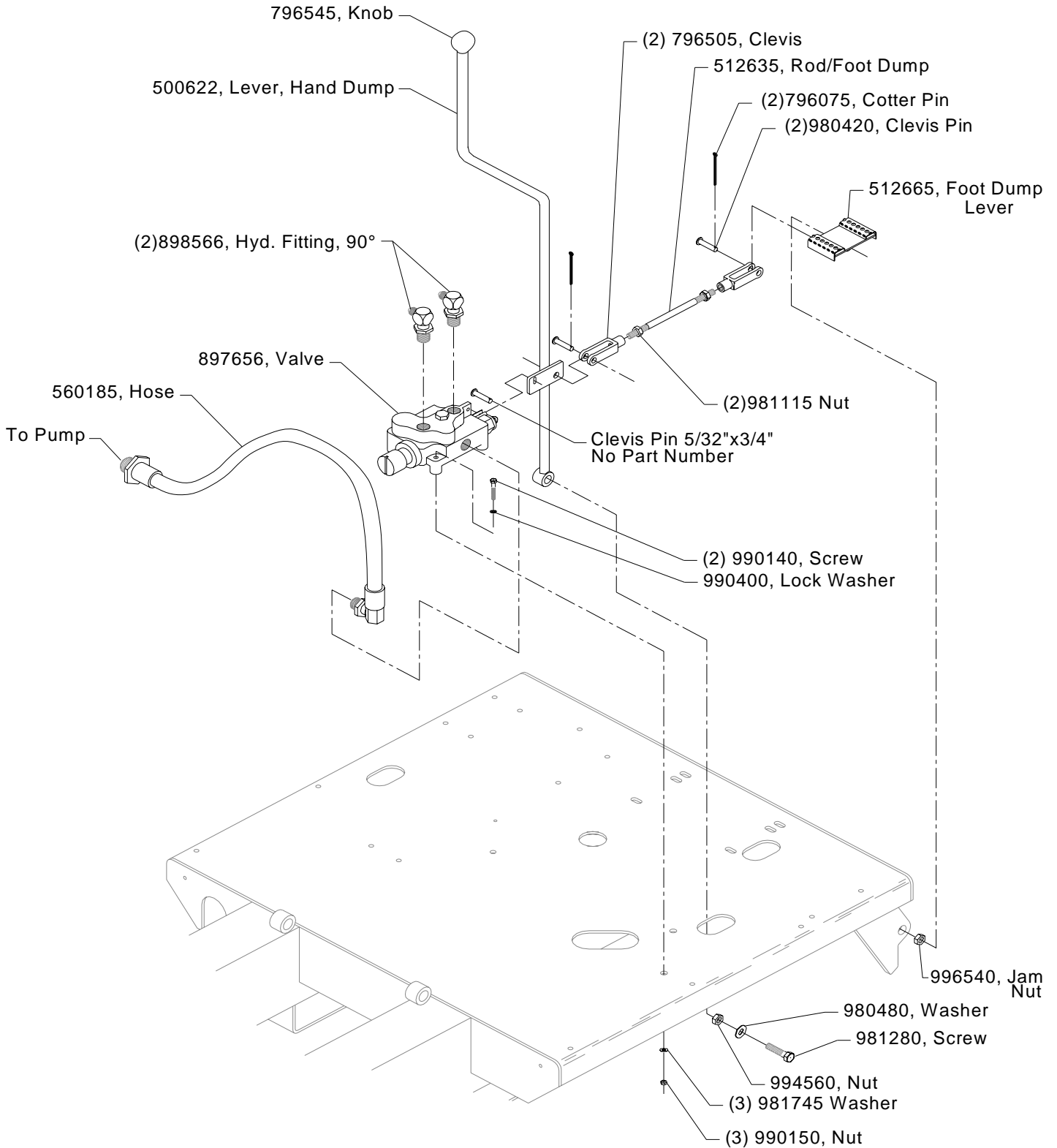



**TEREX**  
LIGHT CONSTRUCTION

Model:

OMP16/21

Title:

Dump Cylinder Assembly

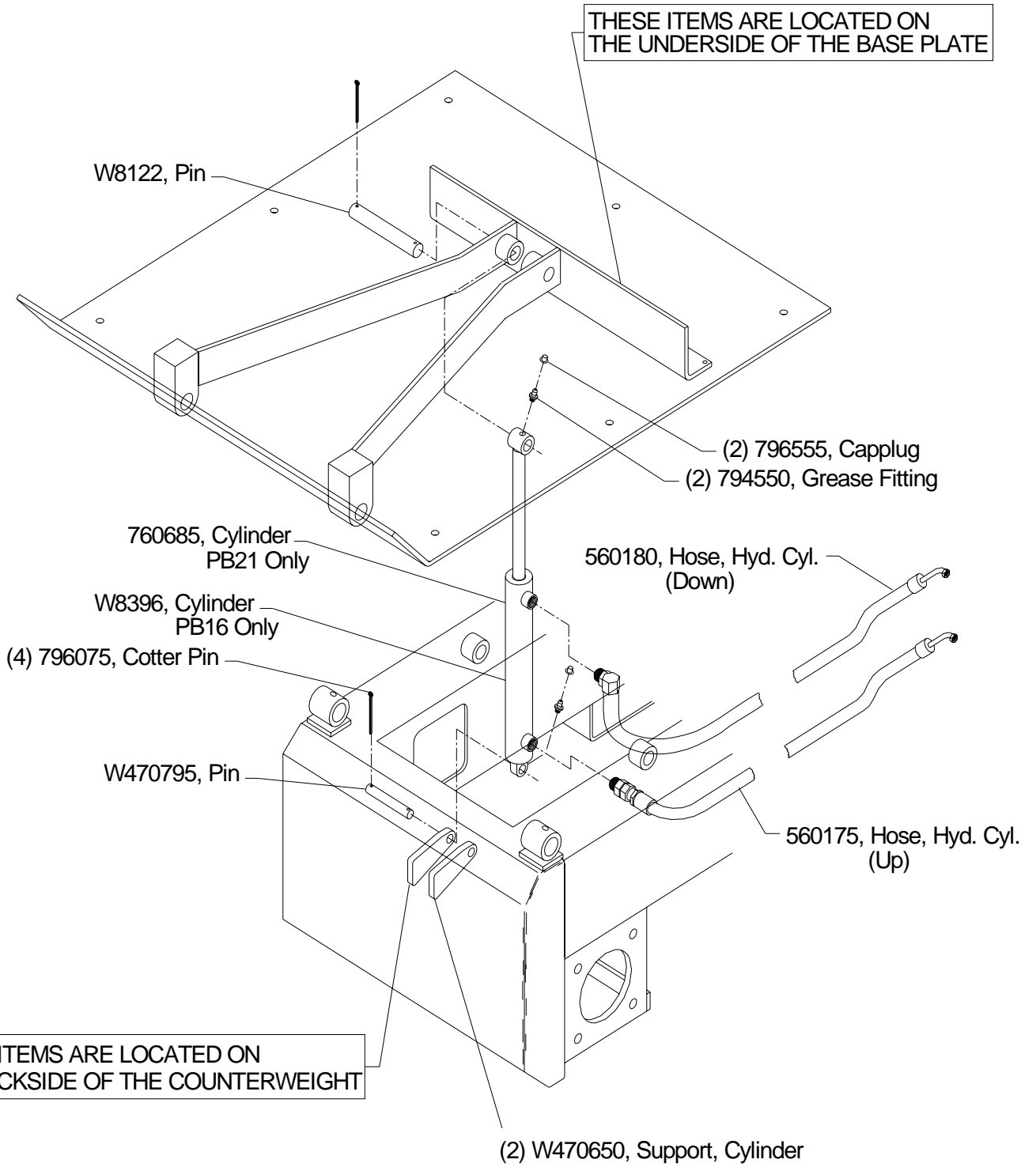



**TEREX**  
LIGHT CONSTRUCTION

Model:

OMP16/21

Title:

Drive Motor Hydraulic System

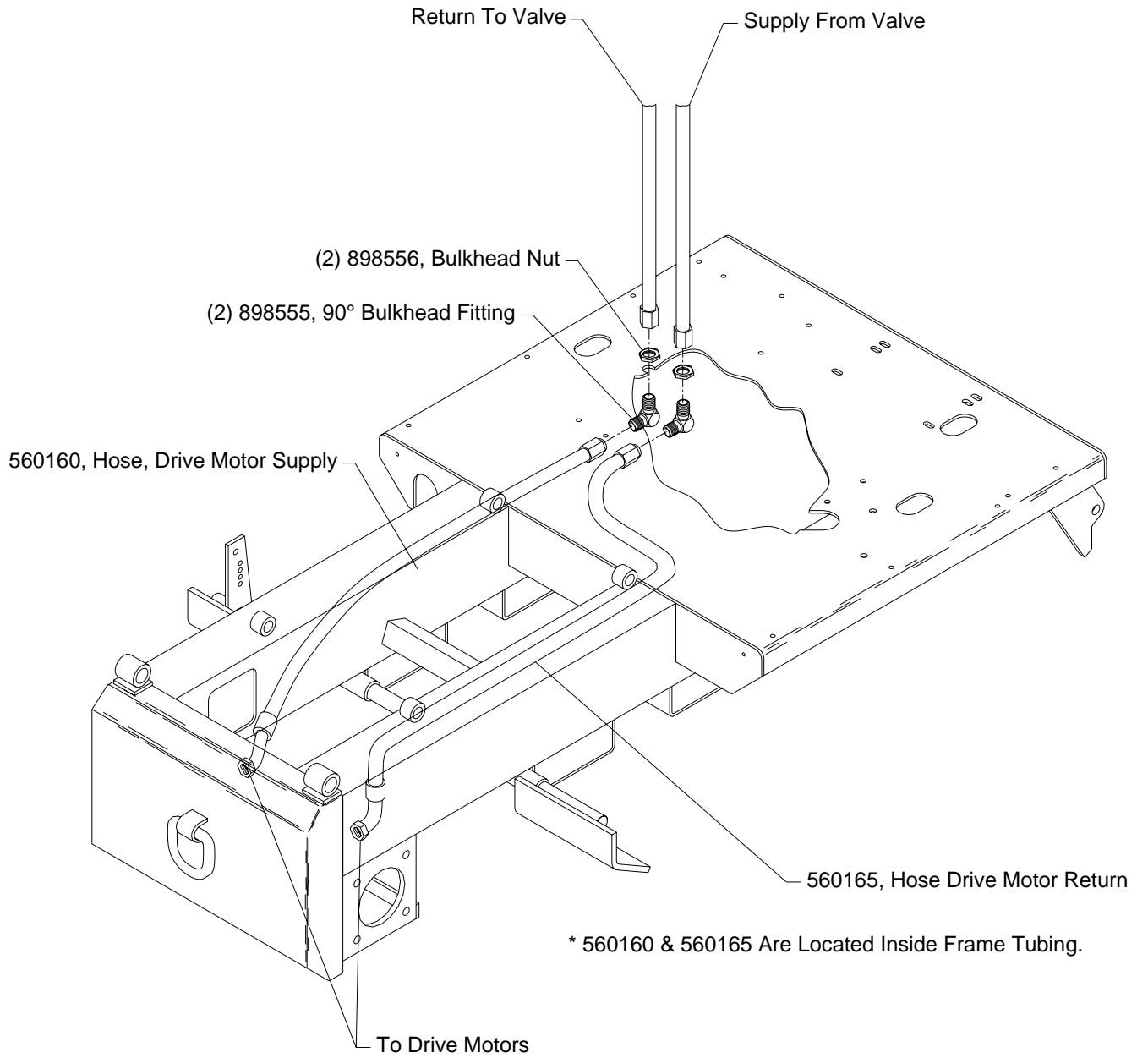



**TEREX**  
LIGHT CONSTRUCTION

Model: OMPB16/21

Title: Drive Motor to Frame Assembly

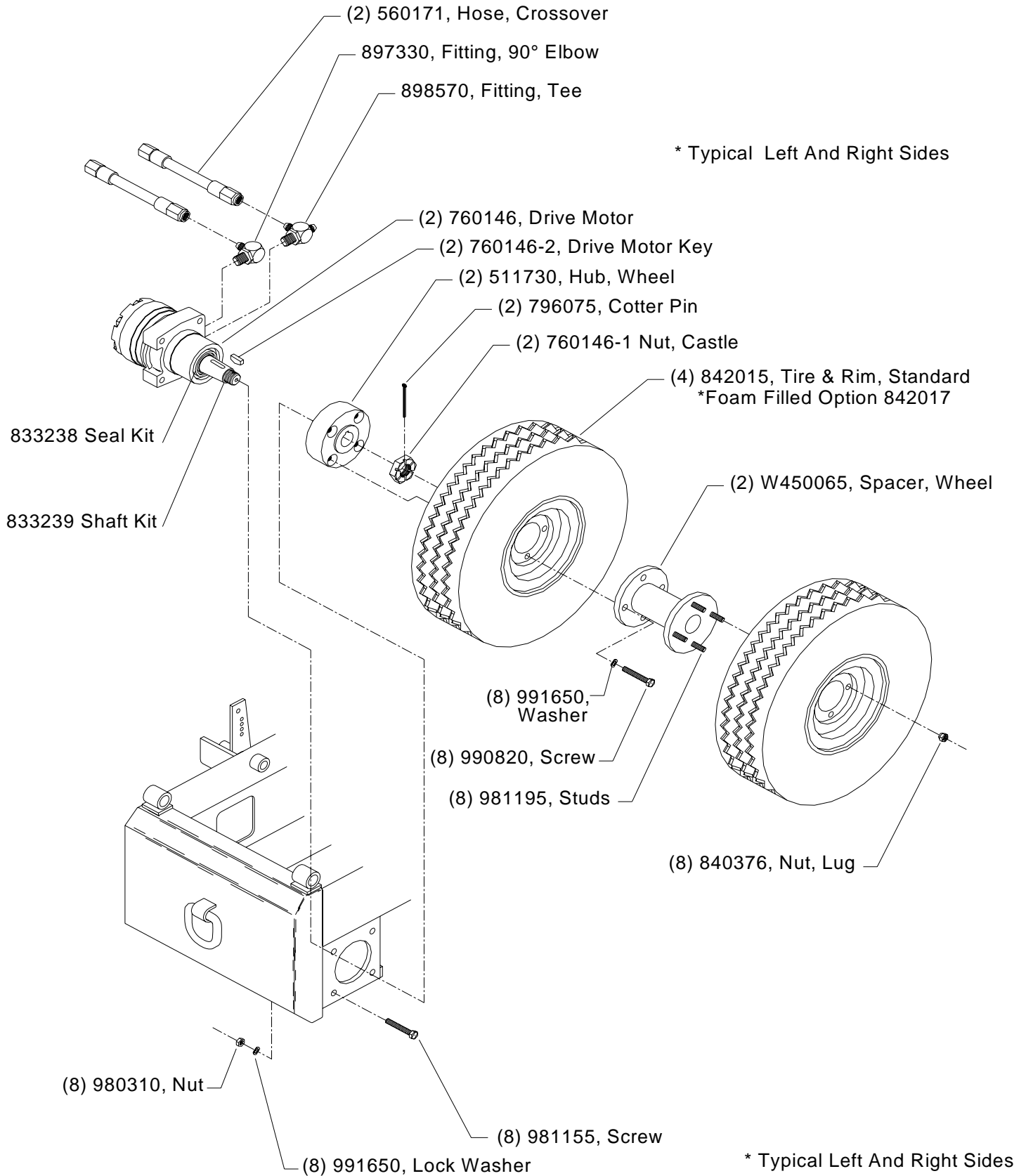



**TEREX**  
LIGHT CONSTRUCTION

|        |                        |
|--------|------------------------|
| Model: | OMP16/21               |
| Title: | Speed Control Assembly |

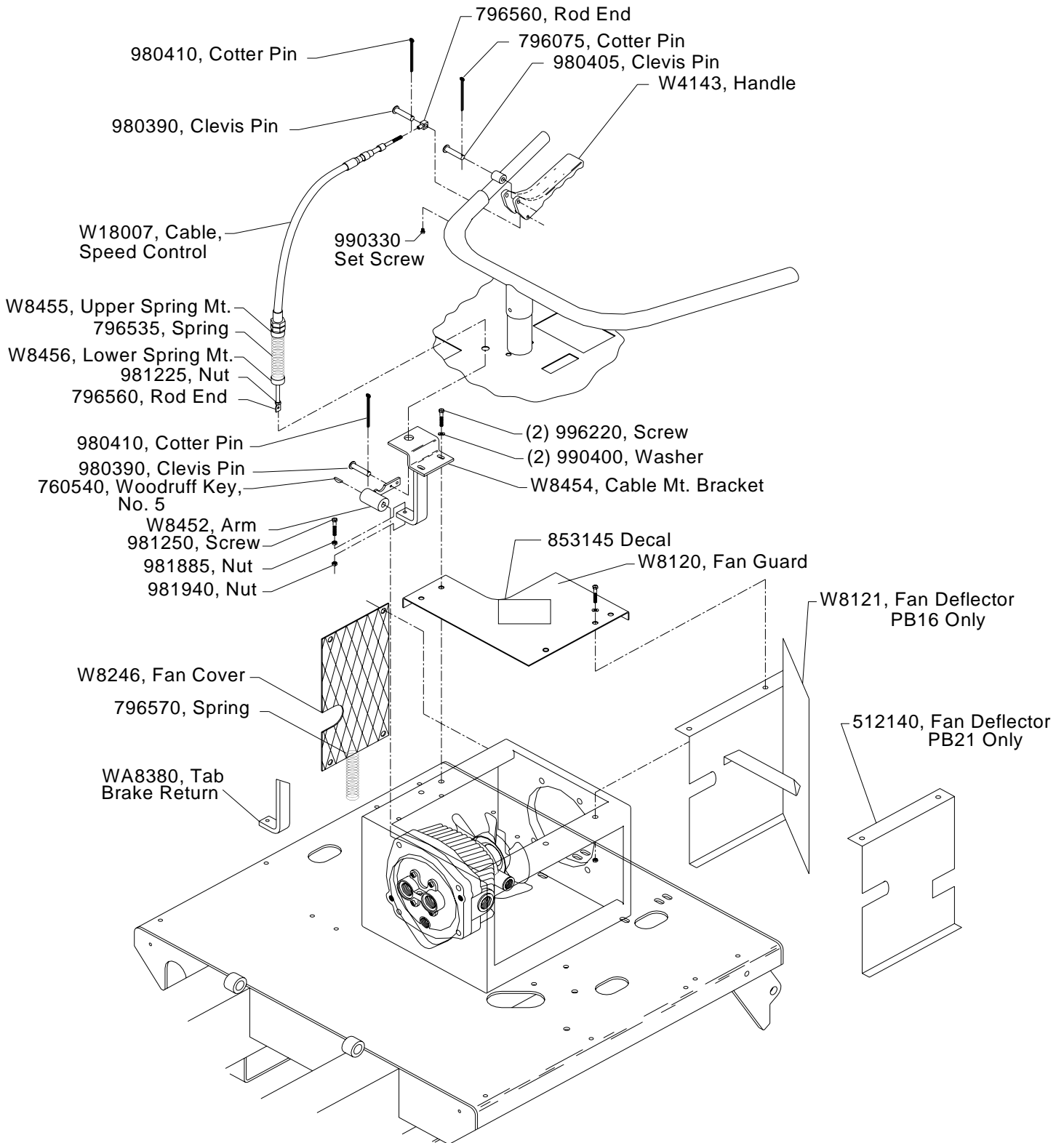



**TEREX**  
LIGHT CONSTRUCTION

Model:

OMP16/21

Title:

Handle Bar to Steering Shaft

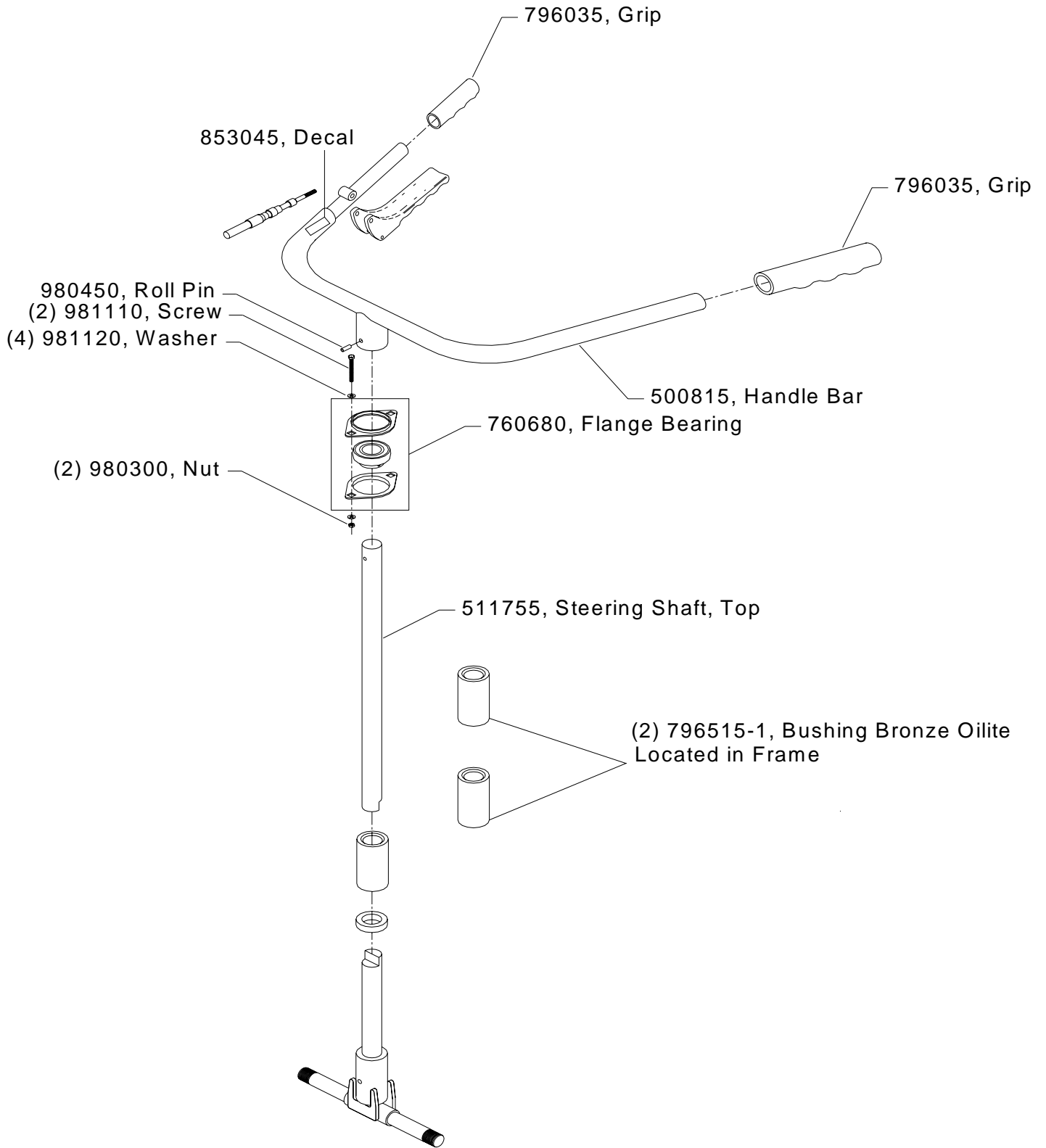

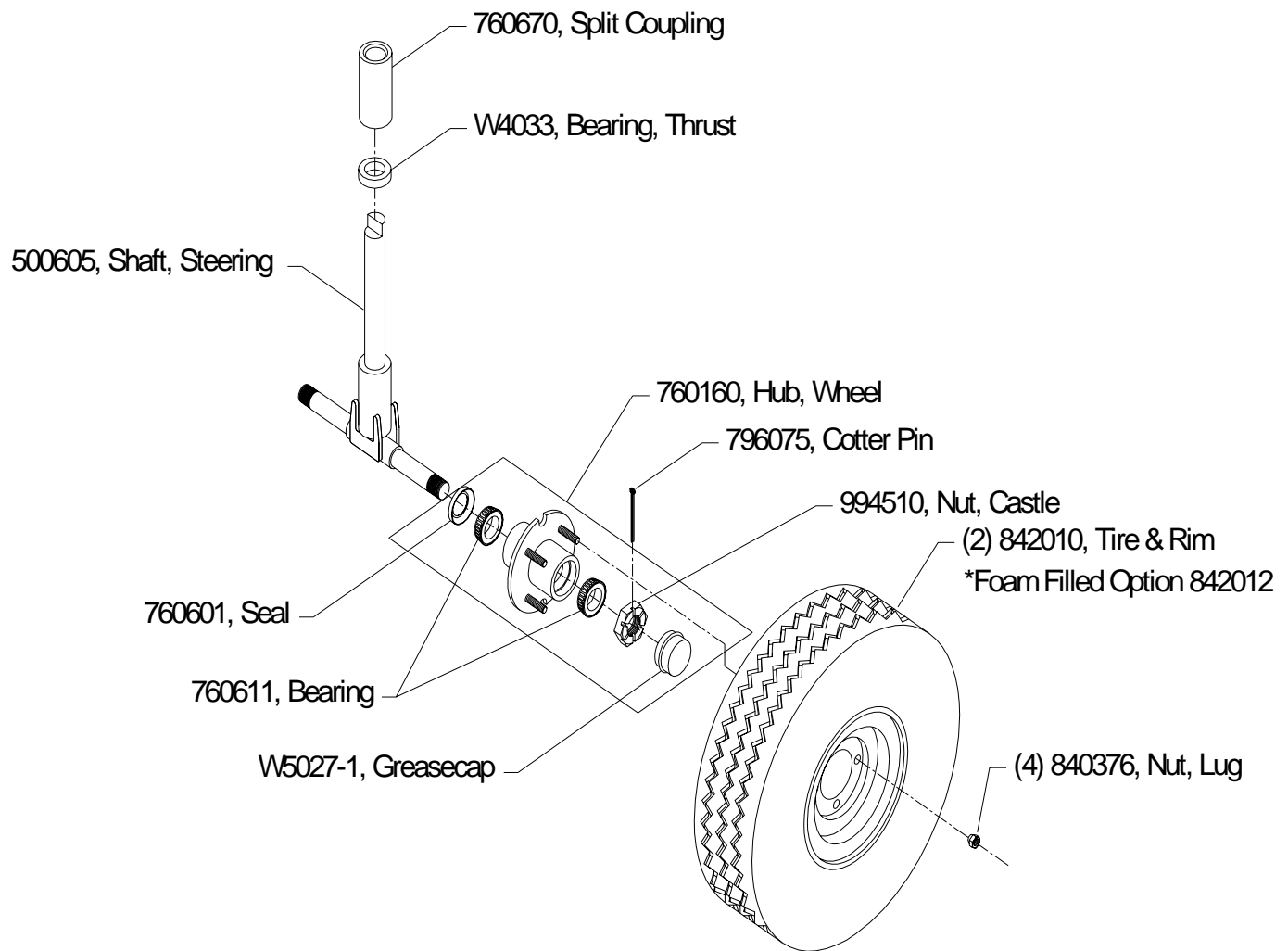



**TEREX**  
LIGHT CONSTRUCTION

Model:

OMP16/21

Title:

Brake / Riding Stand

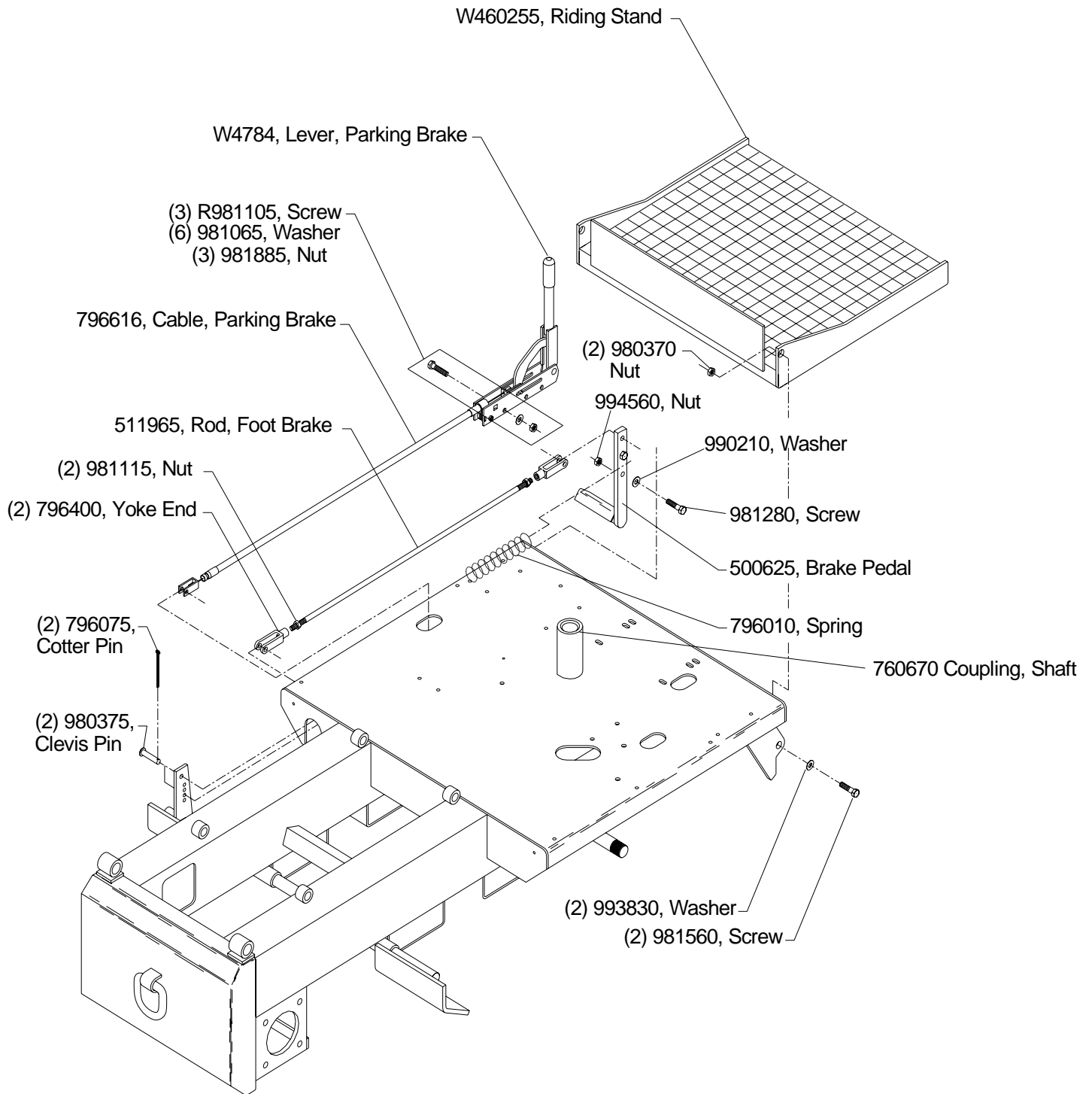



**TEREX**  
LIGHT CONSTRUCTION

Model:

OMP B16

Title:

Plastic Bucket Assembly

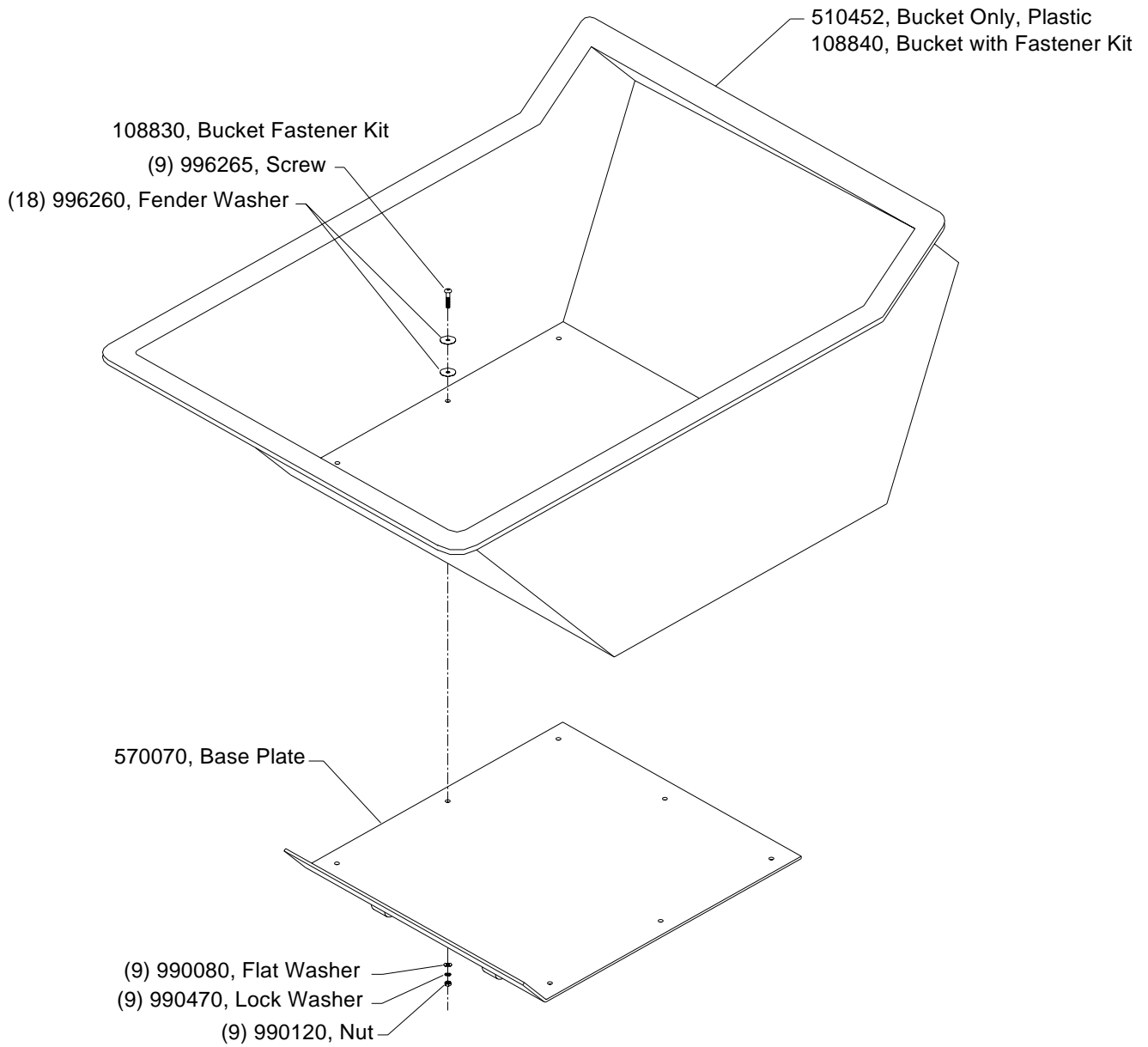



**TEREX**  
LIGHT CONSTRUCTION

Model:

OMP16/21

Title:

Steel Bucket Assembly

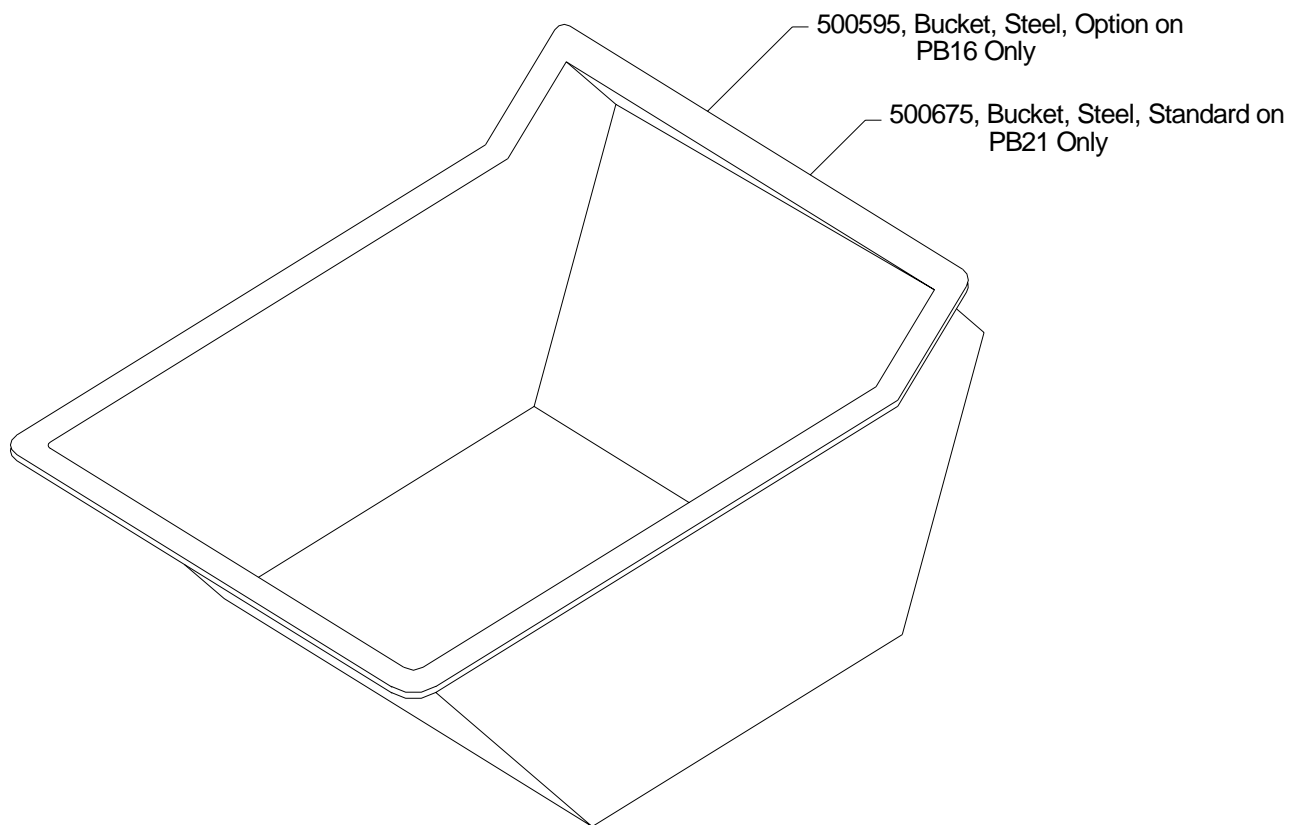



**TEREX**  
LIGHT CONSTRUCTION

Model:

OMP16/21

Title:

Bucket to Frame

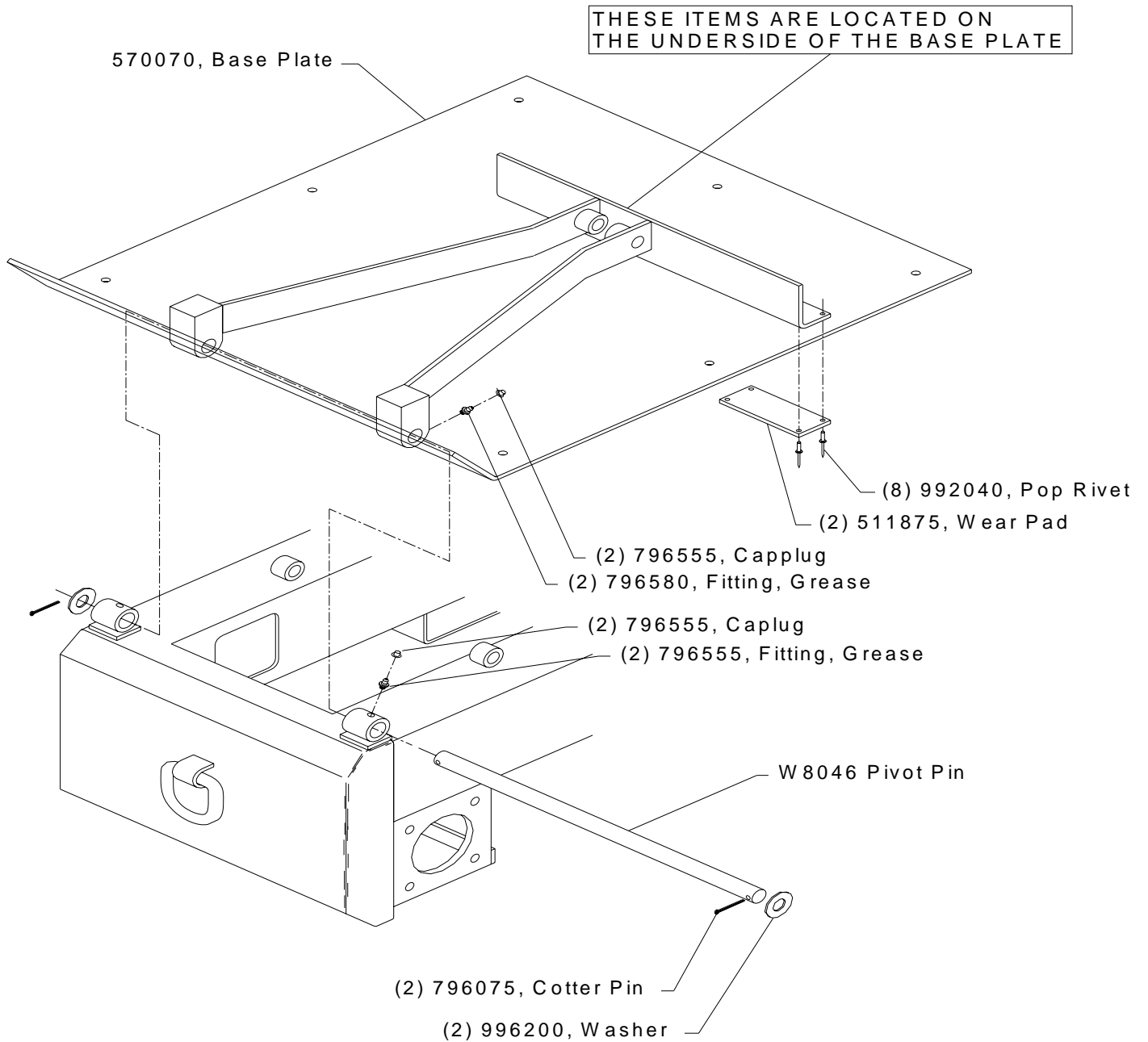



**TEREX**  
LIGHT CONSTRUCTION

Model: OMPB16/21

Title: Engine Cover Assembly

108570 DECAL KIT, PB16  
108575 DECAL KIT, PB21

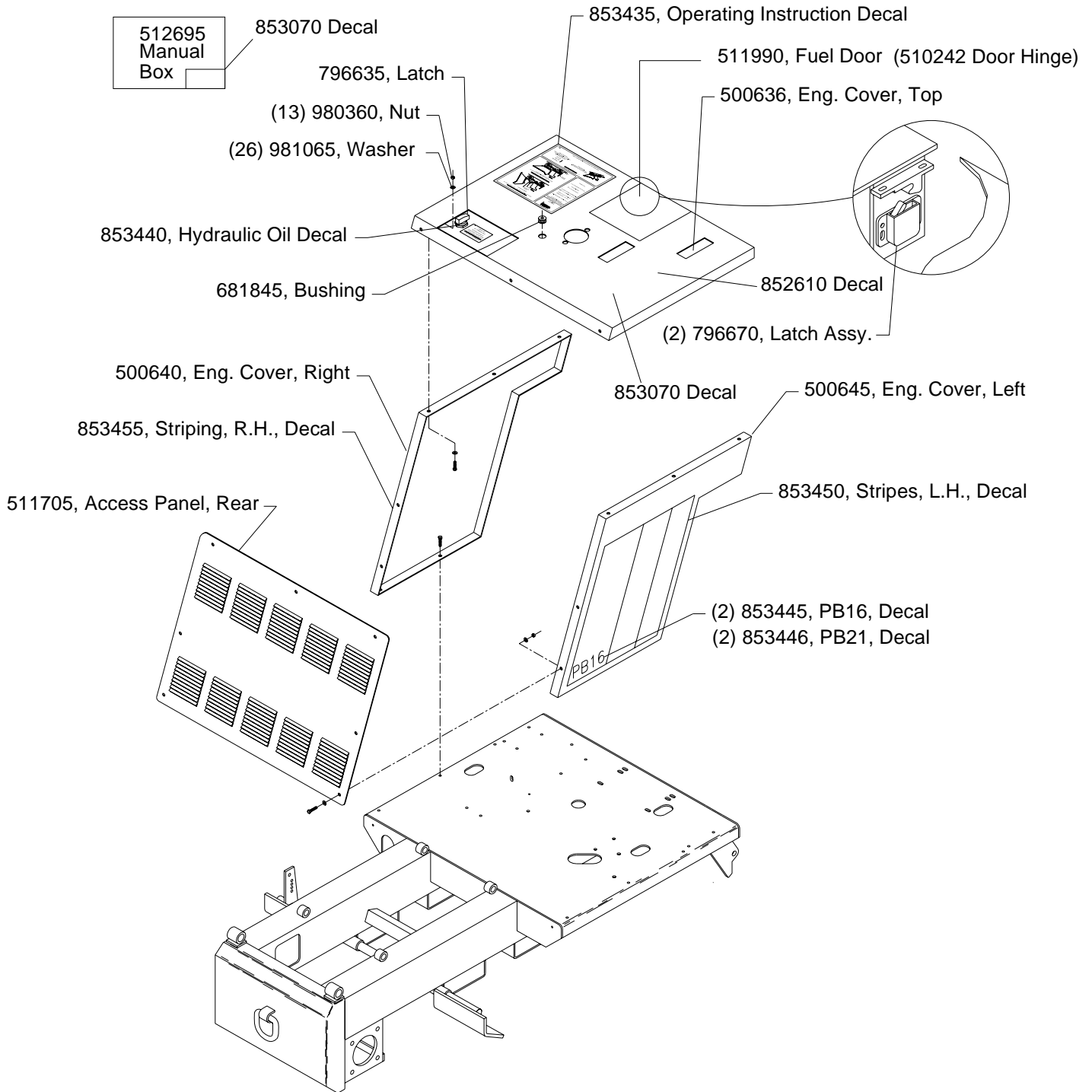



**TEREX**  
LIGHT CONSTRUCTION

Model:

OMP16/21

Title:

Engine Cover Assembly

